

**Royce
Rolls
Ringer
Company**

90
MORE THAN 90 YEARS OF
QUALITY

MANUFACTURED
IN THE USA

428 Stainless Steel Round Bucket & Wringer Combo

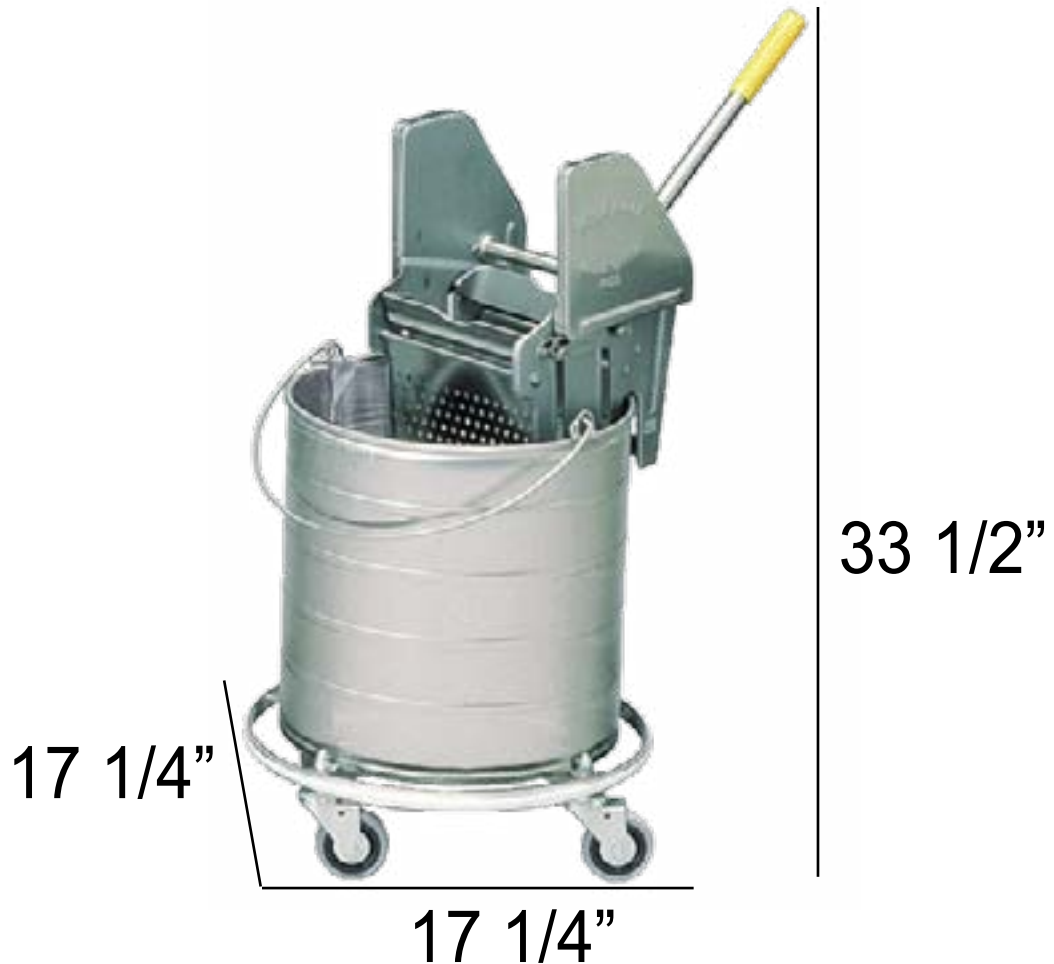

DIMENSIONS

- Overall with Wheelbase is 17 1/4" Diameter x 33 1/2" H.
- 8-Gallon Bucket Only is 14" Diameter x 14" H.
- 16-24 oz. Wringer Only is 10 3/8" W x 19 1/2" H
- Inside Wringer Basket 5" x 8 1/2"

MORE THAN 90 YEARS OF
SERVICE, QUALITY, & CARING

90

ROYCE ROLLS RINGER COMPANY Grand Rapids, Michigan
Since 1925 ALL STAINLESS STEEL PRODUCTS GUARANTEED 10 YEARS
TOLL FREE 1-800-253-9638 FAX 616-361-5976 www.RoyceRolls.net

